



[www.grhpower.com](http://www.grhpower.com)

**GRH POWER**

**POWER UNIT**

**动力单元**

**国瑞液压**





持续的改进和对液压领域的专注，超过三十年的设计及制造经验，GRH从1986年至今取得了引人注目的成就。

产品的研发和技术创新是GRH前进的动力。TS16949和ISO14000的标准是GRH遵守的程序化准则。员工的能力和创造性是GRH不同于竞争对手的主要因素。

GRH设计并生产：液压齿轮泵/片式多路阀/整体多路阀/比例多路阀（带负载敏感及压力补偿）/液压马达/液压分流马达；这些零部件主要应用于工业机械、物料搬运、工程机械、农业和工业领域。GRH充分意识到客户在设计阶段作出的贡献及其产品设计输入的重要性。除了供应GRH目录上的产品，GRH还与客户密切协作提供液压技术的系统解决方案。客户可以依靠GRH在液压元件及系统设计方面的经验及GRH技术专家去实现他们的设想。GRH已关注到电子控制与液压系统集成的重要性，为了优化设计及节约能源，GRH在系统的电子控制及集成化方面正在做出自己的努力。

GRH is specialized in providing hydraulic components and solutions for hydraulic systems. With continuous improvement and enthusiasm over the past 30 years, GRH has developed into an emerging power in the fluid power industry since it was established in 1986.

Research and development are the driving force that facilitates GRH's ability to create new products. Standards of TS16949 and ISO14000 are our guiding principles. Employees' capabilities and creativity are major factors that differentiate GRH from our competitors.

GRH designs and produces Hydraulic Gear Pumps & Motors, Monoblock Valves, Sectional Stack Valves, Proportional Valves and Flow Dividers. These products are used on industrial machinery, construction equipment, agricultural equipment and material handling applications. GRH is also willing to work with our customers to develop specialized products for their special needs. Our customers can count on GRH's extensive system design and application experience when they are designing their hydraulic systems. GRH has designed and developed a series of load sensing proportional stackable valves which provides an improvement in valve operating performance and system efficiency.





汽车举升机用动力单元 - Power Unit for Vehicle Lift	1
剪式升降机用动力单元 - Power Unit for Hydraulic Scissorlift	2
高空作业平台用动力单元 - Power Unit for Aerial Work Platforms	3
半电动堆高车用动力单元 - Power Unit for Semi-electric Stacker	4
全电动堆高车用动力单元 - Power Unit for All-electric Forklift Truck	5
箱式货车用动力单元 - Power Unit for Van Truck	6
汽车尾板用动力单元 - Power Unit for Automobile Tail Plate	7
扒胎机用动力单元 - Power Unit for Tyre Press	8
登车桥用动力单元 - Power Unit for Dock Leveler	9
扫雪车用动力单元 - Power Unit for Snow Removal Truck	10
托盘车动力单元 - Power Unit for Pallet Truck	11
医疗用微型动力单元 - Micro Power Unit for Medical Equipment	12
40种液压原理图 - Hydraulic Schematic	13-19

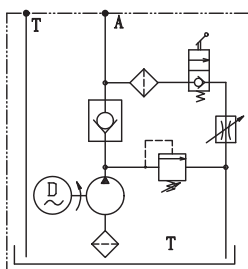

### 简介 FEATURES

此液压力单元由高压齿轮泵、交流电机、液压阀、油箱等零部件有机结合为一体。为双柱汽车举升机提供升降功能，节流阀控制下降，可调节下降速度。

This hydraulic power unit is made up of high pressure gear pump, AC motor, multi-manifold hydraulic valve, oil tank, etc. It enable the two post vehicle lift have the function of lift and fall. The throat valve can control fall speed.

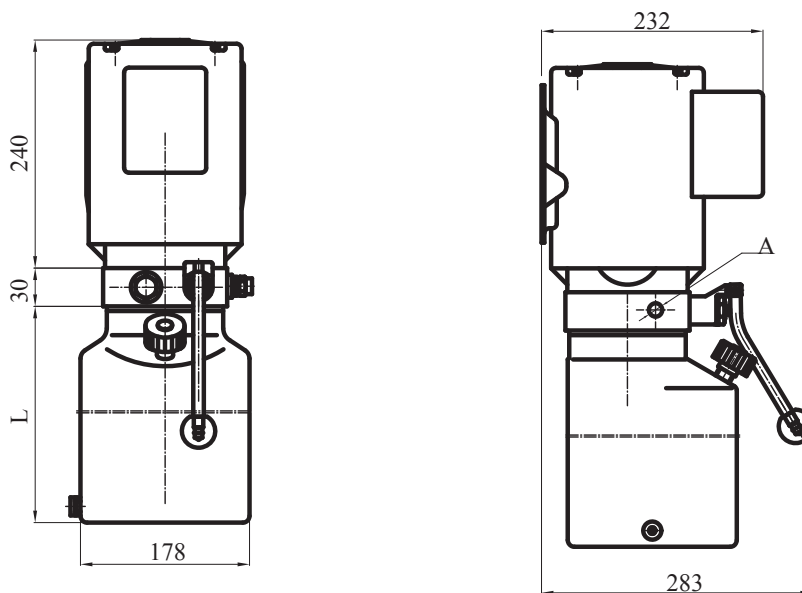

### 型号规格说明 Specifications

型号 Model	电机 Motor	泵排量 Disp.(cc/r)	油箱容积 Tank Cap.(L)	压力 Pressure(MPa)	安装方式 Installation	油口尺寸 Port Size	L(mm)
AC-F5-2.1/F-2.2/220/2850/**-10V-D	220V 2.2Kw 2850RPM 50Hz	2.1	10	20	立式 Vertical	G3/8	440
AC-F5-2.7/F-2.2/220/2850/**-12V-D		2.7	12	18			545
AC-F5-2.1/F-2.2/380/2850/**-10V-D	380V 2.2Kw 2850RPM 50Hz	2.1	10	20			440
AC-F5-2.7/F-2.2/380/2850/**-12V-D		2.7	12	18			545

### 注意事项 Notice

- 1.此动力单元为S3工作制，不可连续运转，可重复工作。
- 2.安装前必须保证油缸、油管、接头等液压元件清洁无任何杂质粘附。
- 3.液压油粘度应为15-68CST，应清洁无杂质，推荐使用N46号液压油；若需全天候工作，必须使用航空液压油。
- 4.本液压力单元为立式安装。
- 5.首次启动运行系统后，应立即检查油箱中的油量是否充足。
- 6.系统使用第一个100小时后，应更换液压油，以后每3000小时更换一次液压油。

- 1.This power unit is S3 working type, can not work continuously, can work repeatedly.
- 2.Before installation, please be sure the cleanliness of component like tank, tube and fittings, without any impurities.
- 3.Viscosity of oil should be 15-68CST, should be clean and without impurities. Suggest to use N46 hydraulic oil. If need to work all-weather, must use aviation hydraulic fluid.
- 4.This power unit is vertical installation.
- 5.After first work, oil tank should be checked immediately to see if there's enough oil.
- 6.After the first 100 working hour, hydraulic oil should be replaced. After that, the oil should be replaced every 3000 working hours.

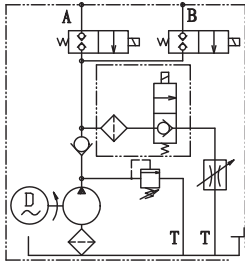

## 简介 FEATURES

此液动力单元采用零泄漏双向止回阀实现两条油路的完全隔离，使得两条油路的上升和下降动作互不干扰，是多缸单独升降系统的理想液压源。该系列动力单元广泛应用于子母台式（大剪）升降机。

This power unit use no-leak Dual way check valve to realize the complete isolation of two line. It make this two line totally independent in the action of lift and fall. It's the ideal hydraulic power for multiple cylinder single lift system. This power unit widely used in primary and secondary (big scissor) fork lifter.

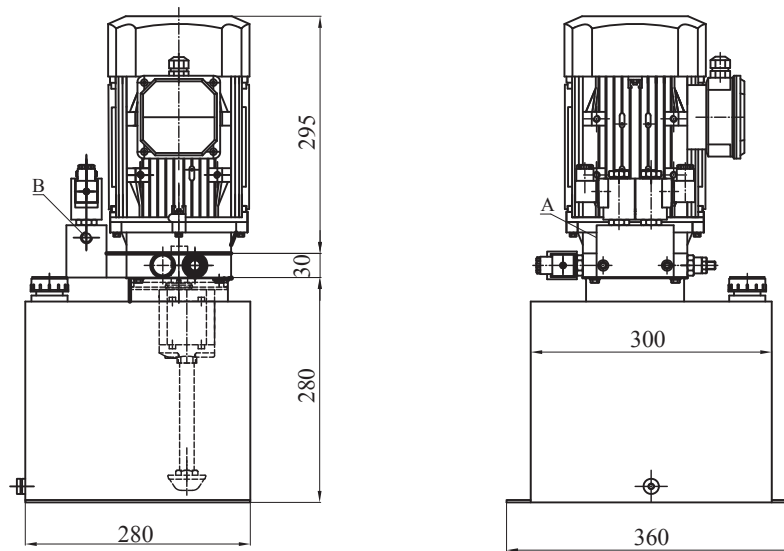

## 型号规格说明 Specifications

型号 Model	电机 Motor	泵排量 Disp.(cc/r)	油箱容积 Tank Cap.(L)	压力 Pressure(MPa)	安装方式 Installation	油口尺寸 Port Size
AC-F9-2.1/F-2.2/220/2850/**-20V-C	220V 2.2Kw 2850RPM 50Hz	2.1	20	20	立式 Vertical	G1/4"
AC-F9-2.1/H-3.0/220/2850/**-20V-C	220V 3.0Kw 2850RPM 50Hz			26		
AC-F9-2.1/G-2.2/380/2850/**-20V-C	380V 2.2Kw 2850RPM 50Hz			22		
AC-F9-2.1/H-3.0/380/2850/**-20V-C	380V 3.0Kw 2850RPM 50Hz			28		

## 注意事项 Notice

- 1.此动力单元为S3工作制，不可连续运转，可重复工作。
- 2.安装前必须保证油缸、油管、接头等液压元件清洁无任何杂质粘附。
- 3.液压油粘度应为15-68CST，应清洁无杂质，推荐使用N46号液压油；若需全天候工作，必须使用航空液压油。
- 4.本液动力单元为立式安装。
- 5.首次启动运行系统后，应立即检查油箱中的油量是否充足。
- 6.系统使用第一个100小时后，应更换液压油，以后每3000小时更换一次液压油。

- 1.This power unit is S3 working type, can not work continuously, can work repeatedly.
- 2.Before installation, please be sure the cleanliness of component like tank, tube and fittings, without any impurities.
- 3.Viscosity of oil should be 15-68CST, should be clean and without impurities. Suggest to use N46 hydraulic oil. If need to work all-weather, must use aviation hydraulic fluid.
- 4.This power unit is vertical installation.
- 5.After first work, oil tank should be checked immediately to see if there's enough oil.
- 6.After the first 100 working hour, hydraulic oil should be replaced. After that, the oil should be replaced every 3000 working hours.

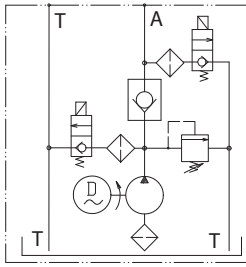

## 简介 FEATURES

此液动力单元由高压齿轮泵、交流电机、多用集成块、液压阀、油箱等零部件有机结合为一体。为高空作业平台提供升降功能,双电阀实现无负载启动。

This power unit is made up of high pressure gear pump, AC motor, multi-manifold, hydraulic valve, oil tank, etc. It provide the lift and fall function for aerial work platforms. With double electric valve, this power unit is able to start without load.

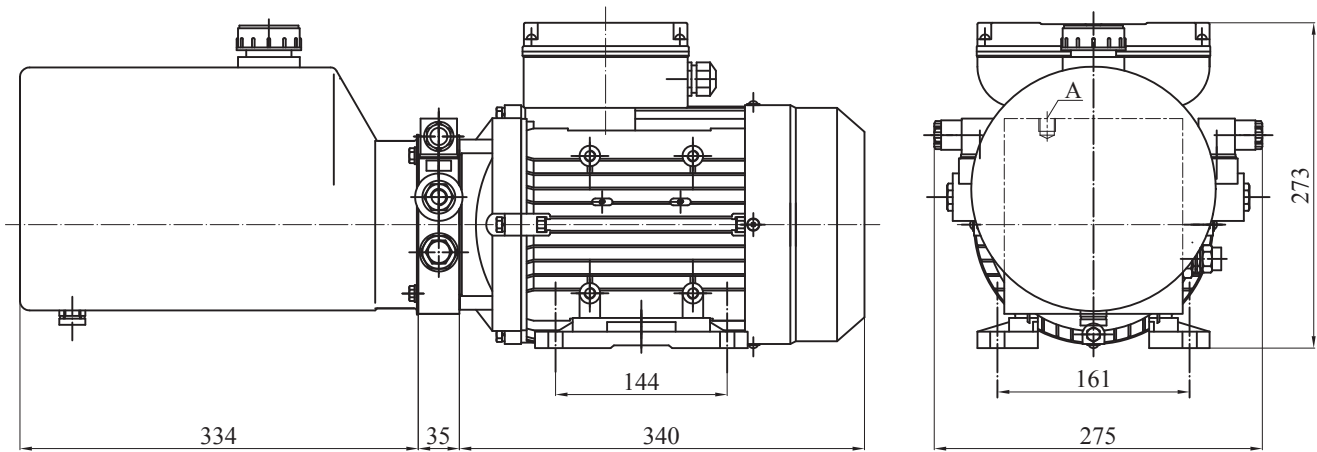

## 型号规格说明 Specifications

型号 Model	电机 Motor	泵排量 Disp.(cc/r)	油箱容积 Tank Cap.(L)	压力 Pressure(MPa)	安装方式 Installation	油口尺寸 Port Size
AC-F11-1.1/F-1.5/220/2850/**-6H-C	220V 1.5Kw 2850RPM 50Hz	1.1	6	18	卧式 Horizontal	G1/4

## 注意事项 Notice

- 1.此动力单元既可以选用S3工作制,不可连续运转,可重复工作,同时也可以选用S1工作制电机
- 2.安装前必须保证油缸、油管、接头等液压元件清洁无任何杂质粘附。
- 3.液压油粘度应为15-68CST,应清洁无杂质,推荐使用N46号液压油;若需全天候工作,必须使用航空液压油。
- 4.本液动力单元适用于立、卧式安装。
- 5.首次启动运行系统后,应立即检查油箱中的油量是否充足。
- 6.系统使用第一个100小时后,应更换液压油,以后每3000小时更换一次液压油。

- 1.This power unit is S3 working type, can not work continuously, can work repeatedly. S1 working type is available too.
- 2.Before installation, please be sure the cleanliness of component like tank, tube and fittings, without any impurities.
- 3.Viscosity of oil should be 15-68CST, should be clean and without impurities. Suggest to use N46 hydraulic oil. If need to work all-weather, must use aviation hydraulic fluid.
- 4.This power unit is available for vertical and horizontal installation.
- 5.After first work, oil tank should be checked immediately to see if there's enough oil.
- 6.After the first 100 working hour, hydraulic oil should be replaced. After that, the oil should be replaced every 3000 working hours.

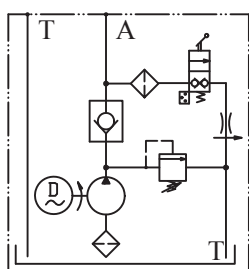

## 简介 FEATURES

此液压力单元专为堆高车设计，由高压齿轮泵、直流电机、多用集成块、液压阀、油箱等零部件有机结合为一体。手动卸荷阀上带有微动开关，堆高车的升和降由卸荷阀的手柄控制，下降速度由内置压力补偿型节流阀自动控制。

This power unit specially design for stackers. It's made up of high pressure gear pump, AC motor, multi-manifold, hydraulic valve, oil tank, etc. There's micro switch on manual unloading valve. The lift and fall action of stacker is controlled by joy sticker of unloading valve. Fall speed is automatically controlled by built-in pressure compensated throttle valve.

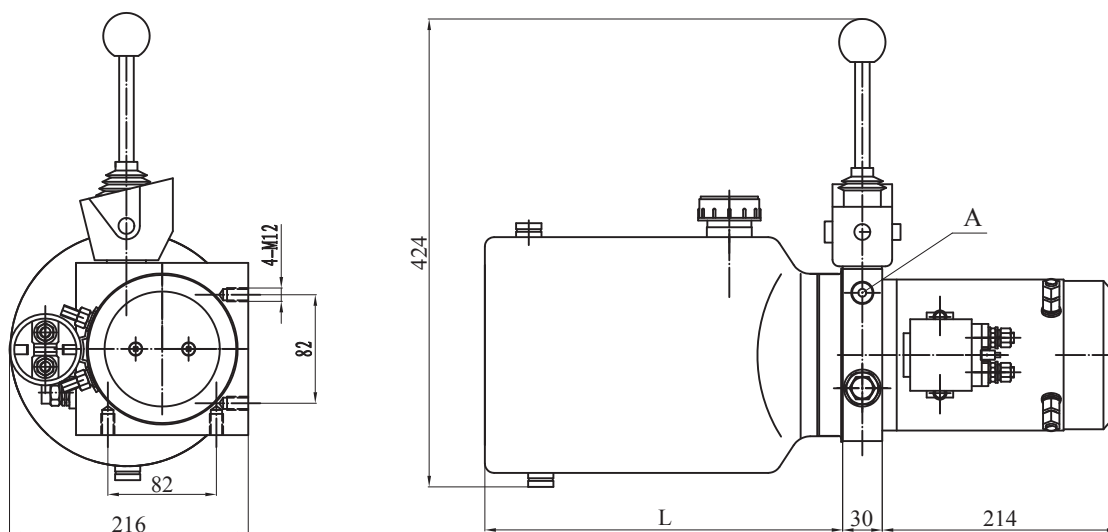

## 型号规格说明 Specifications

型号 Model	电机 Motor	泵排量 Disp.(cc/r)	油箱容积 Tank Cap.(L)	压力 Pressure(MPa)	安装方式 Installation	油口尺寸 Port Size	L(mm)
DC-F6-1.6/F-1.6/12/**-5HS-D	12V 1.6Kw 2500RPM	1.6	5	20	侧卧式 Horizontal	G3/8	270
DC-F6-2.1/F-1.6/12/**-6HS-D		2.1	6				300
DC-F6-2.1/F-2.2/24/**-6HS-D	24V 2.2Kw 2500RPM	2.1	6				300
DC-F6-2.6/F-2.2/24/**-8HS-D		2.6	8				370

## 注意事项 Notice

- 1.此动力单元为S3工作制，不可连续运转，可重复工作。
- 2.安装前必须保证油缸、油管、接头等液压元件清洁无任何杂质粘附。
- 3.液压油粘度应为15-68CST，应清洁无杂质，推荐使用N46号液压油；若需全天候工作，必须使用航空液压油。
- 4.本液压力单元为侧卧式安装。
- 5.首次启动运行系统后，应立即检查油箱中的油量是否充足。
- 6.系统使用第一个100小时后，应更换液压油，以后每3000小时更换一次液压油。

- 1.This power unit is S3 working type, can not work continuously, can work repeatedly.
- 2.Before installation, please be sure the cleanliness of component like tank, tube and fittings, without any impurities.
- 3.Viscosity of oil should be 15-68CST, should be clean and without impurities. Suggest to use N46 hydraulic oil. If need to work all-weather, must use aviation hydraulic fluid.
- 4.This power unit is horizontal installation.
- 5.After first work, oil tank should be checked immediately to see if there's enough oil.
- 6.After the first 100 working hour, hydraulic oil should be replaced. After that, the oil should be replaced every 3000 working hours.



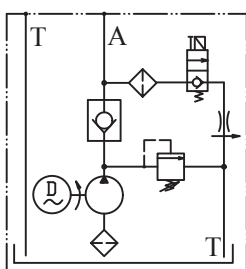

## 简介 FEATURES

此液压力单元由高压齿轮泵、直流电机、多用集成块、液压阀、油箱等零部件有机结合为一体。系典型的动力上升、重力下降液压回路。启动电机,实现上升,打开电磁卸荷阀,实现下降,下降速度由内置压力补偿型流量控制阀自动控制。本系列产品是各种堆高车、小型升降平台等物流设备的理想动力源。

This hydraulic power unit is made up of high pressure gear pump, AC motor, multi-manifold, hydraulic valve, oil tank, etc. It is a typical power up, gravity down hydraulic circuits. Start the motor, it rise; Open electromagnetic unloading valve, it drop, falling speed automatic controlled by the built-in pressure compensated flow control valve. This series is ideal power supplier for logistics facilities, such as all sorts of fork truck, small lift platform etc.

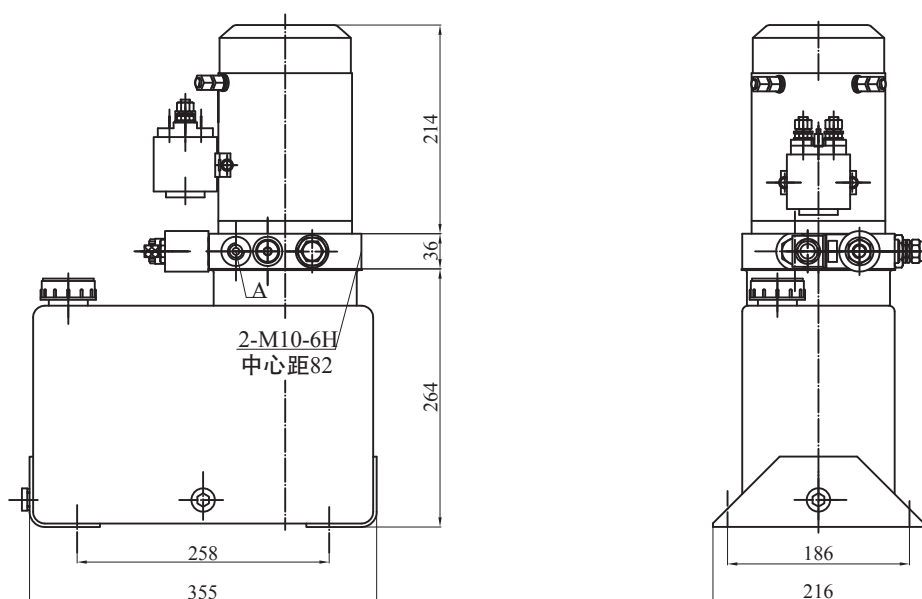

## 型号规格说明 Specifications

型号 Model	电机 Motor	泵排量 Disp.(cc/r)	油箱容积 Tank Cap.(L)	压力 Pressure(MPa)	安装方式 Installation	油口尺寸 Port Size
DC-F10S-1.6/F-1.6/12/**-7V-D	12V 1.6Kw 2500RPM	1.6	7	20	立式 Vertical	G3/8
DC-F10S-2.6/F-2.2/24/**-7V-D	24V 2.2Kw 2500RPM	2.6				

## 注意事项 Notice

- 1.此动力单元为S3工作制,不可连续运转,可重复工作。
- 2.安装前必须保证油缸、油管、接头等液压元件清洁无任何杂质粘附。
- 3.液压油粘度应为15-68CST,应清洁无杂质,推荐使用N46号液压油;若需全天候工作,必须使用航空液压油。
- 4.本液压力单元为立式安装。
- 5.首次启动运行系统后,应立即检查油箱中的油量是否充足。
- 6.系统使用第一个100小时后,应更换液压油,以后每3000小时更换一次液压油。

- 1.This power unit is S3 working type, can not work continuously, can work repeatedly.
- 2.Before installation, please be sure the cleanliness of component like tank, tube and fittings, without any impurities.
- 3.Viscosity of oil should be 15-68CST, should be clean and without impurities. Suggest to use N46 hydraulic oil. If need to work all-weather, must use aviation hydraulic fluid.
- 4.This power unit is vertical installation.
- 5.After first work, oil tank should be checked immediately to see if there's enough oil.
- 6.After the first 100 working hour, hydraulic oil should be replaced. After that, the oil should be replaced every 3000 working hours.

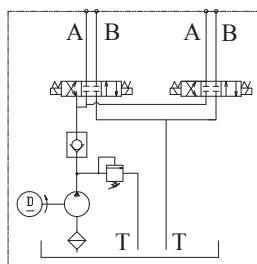

## 简介 FEATURES

此液动力单元由高压齿轮泵、直流电机、多用集成块、液压阀、油箱等零部件有机结合为一体。为箱式货车提供展翼功能，可供4支双作用油缸使用。

This hydraulic power unit is made up of high pressure gear pump, AC motor, multi-manifold, hydraulic valve, oil tank, etc. It permit usage for four double action tank , provide wing opening function for van truck,

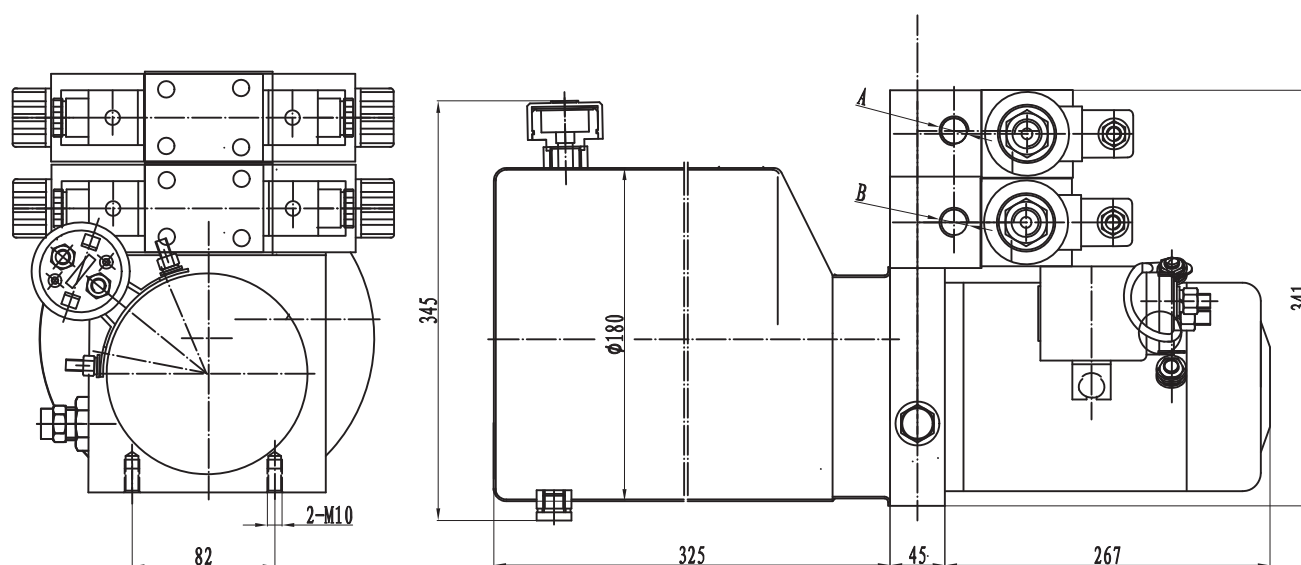

## 型号规格说明 Specifications

型号 Model	电机 Motor	泵排量 Disp.(cc/r)	油箱容积 Tank Cap.(L)	压力 Pressure(MPa)	安装方式 Installation	油口尺寸 Port Size
DC-F39-2.5/E-2/24/**-8H-A	24V 2Kw 2800RPM 50Hz	2.5	8	14	卧式 Horizontal	M14×1.5

## 注意事项 Notice

- 1.此动力单元为S3工作制，不可连续运转，可重复工作。
- 2.安装前必须保证油缸、油管、接头等液压元件清洁无任何杂质粘附。
- 3.液压油粘度应为15-68CST，应清洁无杂质，推荐使用N46号液压油；若需全天候工作，必须使用航空液压油。
- 4.本液动力单元为卧式安装。
- 5.首次启动运行系统后，应立即检查油箱中的油量是否充足。
- 6.系统使用第一个100小时后，应更换液压油，以后每3000小时更换一次液压油。

- 1.This power unit is S3 working type, can not work continuously, can work repeatedly.
- 2.Before installation, please be sure the cleanliness of component like tank, tube and fittings, without any impurities.
- 3.Viscosity of oil should be 15-68CST, should be clean and without impurities. Suggest to use N46 hydraulic oil. If need to work all-weather, must use aviation hydraulic fluid.
- 4.This power unit is horizontal installation.
- 5.After first work, oil tank should be checked immediately to see if there's enough oil.
- 6.After the first 100 working hour, hydraulic oil should be replaced. After that, the oil should be replaced every 3000 working hours.

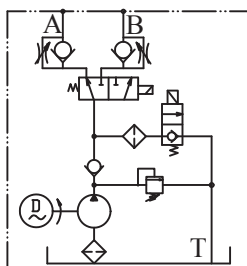

### 简介 FEATURES

此液压力单元由高压齿轮泵、交流电机、多用集成块、液压阀、油箱等零部件有机结合为一体。为汽车尾板提供升降开闭功能，箱式组合便于运输安装。

This hydraulic power unit is made up of high pressure gear pump, AC motor, multi-manifold, hydraulic valve, oil tank, etc. It provide lift, down, open and close function for automobile tail plate, box type combination is convenient for transportation installation.

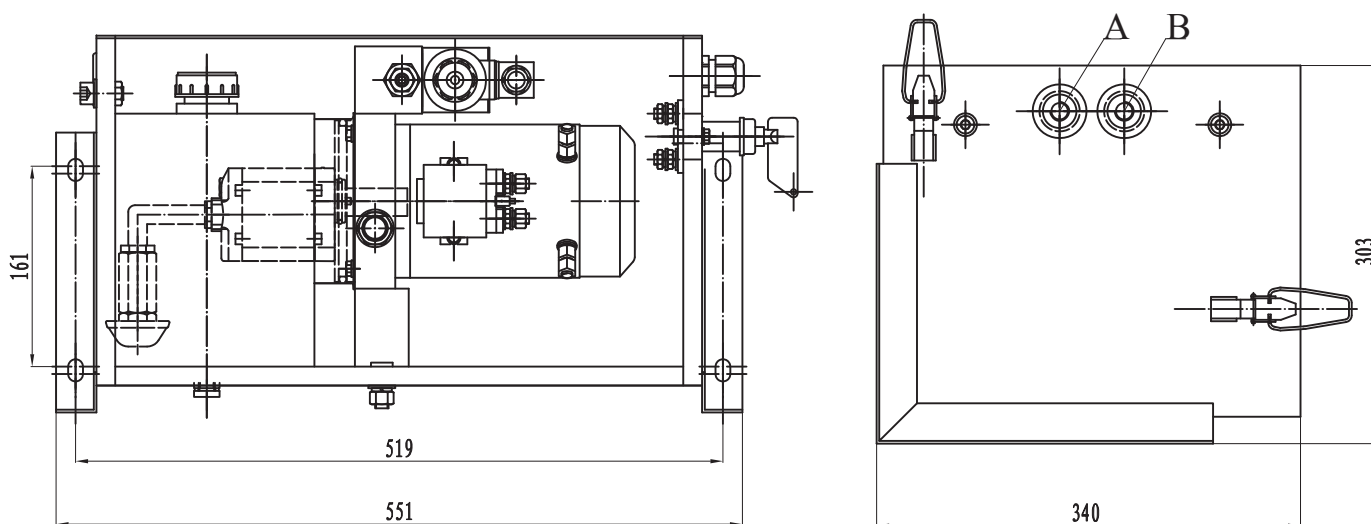

### 型号规格说明 Specifications

型号 Model	电机 Motor	泵排量 Disp.(cc/r)	油箱容积 Tank Cap.(L)	压力 Pressure(MPa)	安装方式 Installation	油口尺寸 Port Size
DC-F15-2.1/F-2.0/12/**-9H-A	12V 2.0Kw 2500RPM	2.1	9	20	卧式 Horizontal	M14×1.5
DC-F15-2.1/F-2.2/24/**-9H-A	24V 2.2Kw 2500RPM					

### 注意事项 Notice

- 1.此动力单元为S3工作制，不可连续运转，可重复工作。
- 2.安装前必须保证油缸、油管、接头等液压元件清洁无任何杂质粘附。
- 3.液压油粘度应为15-68CST，应清洁无杂质，推荐使用N46号液压油；若需全天候工作，必须使用航空液压油。
- 4.本液压力单元为卧式安装。
- 5.首次启动运行系统后，应立即检查油箱中的油量是否充足。
- 6.系统使用第一个100小时后，应更换液压油，以后每3000小时更换一次液压油。

- 1.This power unit is S3 working type, can not work continuously, can work repeatedly.
- 2.Before installation, please be sure the cleanliness of component like tank, tube and fittings, without any impurities.
- 3.Viscosity of oil should be 15-68CST, should be clean and without impurities. Suggest to use N46 hydraulic oil. If need to work all-weather, must use aviation hydraulic fluid.
- 4.This power unit is horizontal installation.
- 5.After first work, oil tank should be checked immediately to see if there's enough oil.
- 6.After the first 100 working hour, hydraulic oil should be replaced. After that, the oil should be replaced every 3000 working hours.

# 扒胎机用动力单元 Power Unit for Tyre Press

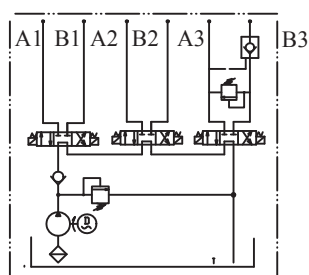

## 简介 FEATURES

此液压力单元由高压齿轮泵、交流电机、多用集成块、液压阀、油箱等零部件有机结合为一体。为汽车扒胎机设计，控制三组双作用油缸。

This hydraulic power unit is made up of high pressure gear pump, AC motor, multi-manifold, hydraulic valve, oil tank, etc. It is designed for tyre press, controlling 3 sets of double-acting cylinder.

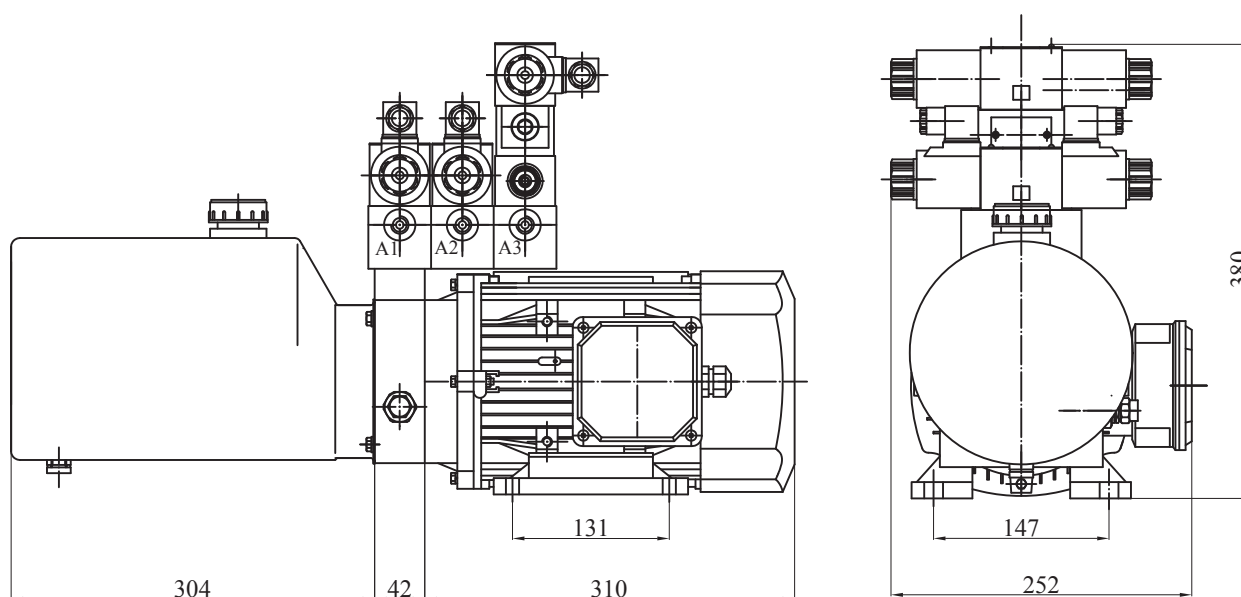

## 型号规格说明 Specifications

型号 Model	电机 Motor	泵排量 Disp.(cc/r)	油箱容积 Tank Cap.(L)	压力 Pressure(MPa)	安装方式 Installation	油口尺寸 Port Size
AC-F40-3.2/F-1.5/380/1440/**-6H-C	380V 1.5Kw 1440RPM 50Hz	3.2	6	18	卧式 Horizontal	G1/4
AC-F40-4.2/F-2.2/380/1440/**-6H-C	380V 2.2Kw 1440RPM 50Hz	4.2		20		

## 注意事项 Notice

- 1.此动力单元为S3工作制，不可连续运转，可重复工作。
  - 2.安装前必须保证油缸、油管、接头等液压元件清洁无任何杂质粘附。
  - 3.液压油粘度应为15-68CST，应清洁无杂质，推荐使用N46号液压油；若需全天候工作，必须使用航空液压油。
  - 4.本液压力单元为卧式安装。
  - 5.首次启动运行系统后，应立即检查油箱中的油量是否充足。
  - 6.系统使用第一个100小时后，应更换液压油，以后每3000小时更换一次液压油。
- 1.This power unit is S3 working type, can not work continuously, can work repeatedly.
  - 2.Before installation, please be sure the cleanliness of component like tank, tube and fittings, without any impurities.
  - 3.Viscosity of oil should be 15-68CST, should be clean and without impurities. Suggest to use N46 hydraulic oil. If need to work all-weather, must use aviation hydraulic fluid.
  - 4.This power unit is horizontal installation.
  - 5.After first work, oil tank should be checked immediately to see if there's enough oil.
  - 6.After the first 100 working hour, hydraulic oil should be replaced. After that, the oil should be replaced every 3000 working hours.

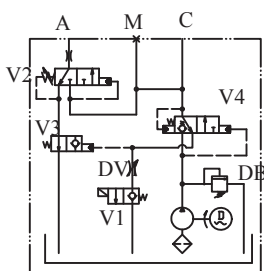

## 简介 FEATURES

此液压动力单元由高压齿轮泵、交流电机、液压阀、油箱等零部件有机结合为一体。为液压登车桥提供大小桥板的升降和闭合功能，可控制两组单作用油缸。

This hydraulic power unit is made up of high pressure gear pump, AC motor, multi-manifold hydraulic valve, oil tank, etc. It enable the dock leveler Axle lift have the function of making unequal-sized bridge plate lift and fall and close up. It could control 2 single-acting cylinder.

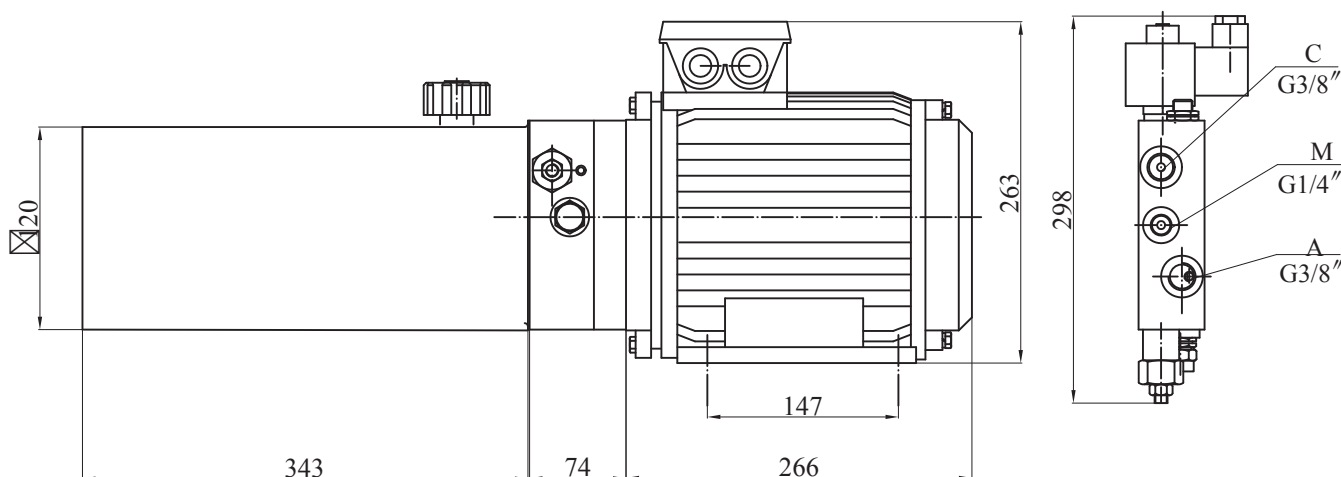

## 型号规格说明 Specifications

型号 Model	电机 Motor	泵排量 Disp.(cc/r)	油箱容积 Tank Cap.(L)	压力 Pressure(MPa)	安装方式 Installation	油口尺寸 Port Size
AC-F32-3.2/E-1.5/380/1440/**-6H-C	380V 1.5Kw 1440RPM 50Hz	3.2	6	16	卧式 Horizontal	G1/4

## 注意事项 Notice

- 1.此动力单元为S3工作制，不可连续运转，可重复工作。
- 2.安装前必须保证油缸、油管、接头等液压元件清洁无任何杂质粘附。
- 3.液压油粘度应为15-68CST，应清洁无杂质，推荐使用N46号液压油；若需全天候工作，必须使用航空液压油。
- 4.本液压动力单元为卧式安装。
- 5.首次启动运行系统后，应立即检查油箱中的油量是否充足。
- 6.系统使用第一个100小时后，应更换液压油，以后每3000小时更换一次液压油。

- 1.This power unit is S3 working type, can not work continuously, can work repeatedly.
- 2.Before installation, please be sure the cleanliness of component like tank, tube and fittings, without any impurities.
- 3.Viscosity of oil should be 15-68CST, should be clean and without impurities. Suggest to use N46 hydraulic oil. If need to work all-weather, must use aviation hydraulic fluid.
- 4.This power unit is horizontal installation.
- 5.After first work, oil tank should be checked immediately to see if there's enough oil.
- 6.After the first 100 working hour, hydraulic oil should be replaced. After that, the oil should be replaced every 3000 working hours.

# 扫雪车用动力单元 Power Unit for Snow Removal Truck

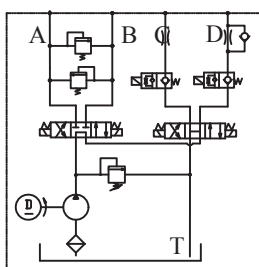

## 简介 FEATURES

此液动力单元由高压齿轮泵、直流电机、多用集成块、液压阀、油箱等零部件有机结合为一体。为扫雪车提供升降和角度调节功能，可同时控制一只双作用油缸及两只单作用油缸。

This hydraulic power unit is made up of high pressure gear pump, AC motor, multi-manifold, hydraulic valve, oil tank, etc. It enable the snow removal truck have the function of lift, fall and angle adjustment. This could control both the double-acting oil cylinder and single-acting oil cylinder in the same time.

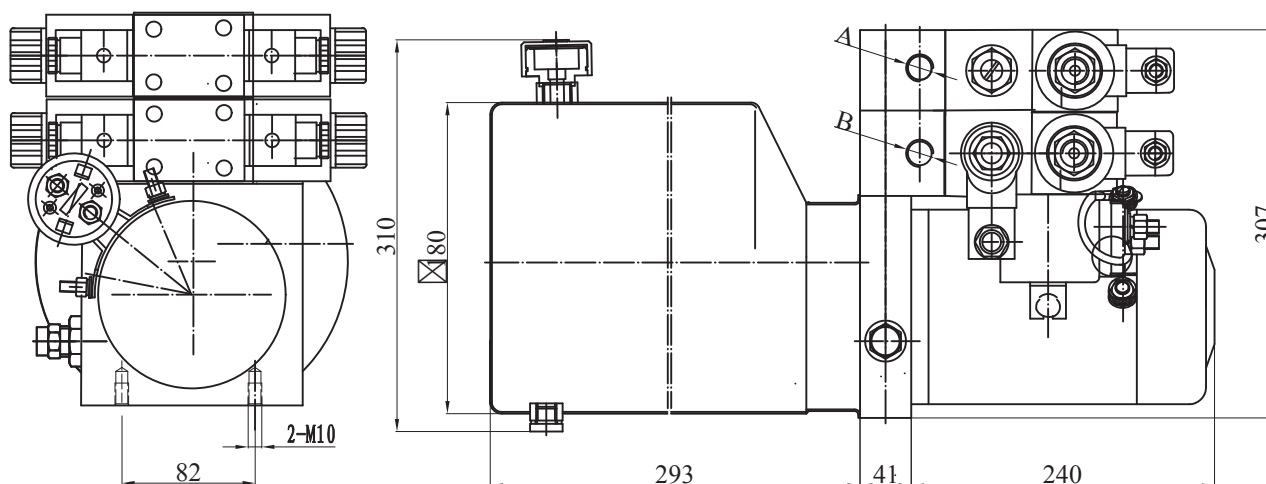

## 型号规格说明 Specifications

型号 Model	电机 Motor	泵排量 Disp.(cc/r)	油箱容积 Tank Cap.(L)	压力 Pressure(MPa)	安装方式 Installation	油口尺寸 Port Size
DC-F36-1.6/F-1.6/12/**-5H-C	12V 1.6Kw 2500RPM	1.6	5	20	卧式 Horizontal	G1/4

## 注意事项 Notice

1. 此动力单元为S3工作制，不可连续运转，可重复工作。
2. 安装前必须保证油缸、油管、接头等液压元件清洁无任何杂质粘附。
3. 液压油粘度应为15-68CST，应清洁无杂质，推荐使用N46号液压油；若需全天候工作，必须使用航空液压油。
4. 本液动力单元为卧式安装。
5. 首次启动运行系统后，应立即检查油箱中的油量是否充足。
6. 系统使用第一个100小时后，应更换液压油，以后每3000小时更换一次液压油。

1. This power unit is S3 working type, can not work continuously, can work repeatedly.
2. Before installation, please be sure the cleanliness of component like tank, tube and fittings, without any impurities.
3. Viscosity of oil should be 15-68CST, should be clean and without impurities. Suggest to use N46 hydraulic oil. If need to work all-weather, must use aviation hydraulic fluid.
4. This power unit is horizontal installation.
5. After first work, oil tank should be checked immediately to see if there's enough oil.
6. After the first 100 working hour, hydraulic oil should be replaced. After that, the oil should be replaced every 3000 working hours.

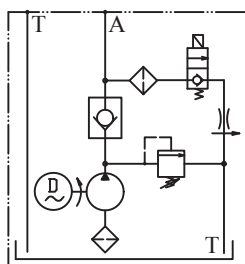

## 简介 FEATURES

此液压微型动力单元由高压齿轮泵、直流电机、多用集成块、液压阀、油箱等零部件有机结合为一体。通常用作轻型堆高车、托盘车的动力源。电磁卸荷阀卸荷实现回油，下降速度由压力补偿型流量控制阀控制。

This hydraulic power unit is made up of high pressure gear pump, AC motor, multi-manifold, hydraulic valve, oil tank, etc. It used at the power origin of light fork truck and pallet truck. Electro-magnetic unloading valve unloading to oil return, decline speed is controlled by pressure compensating flow control valve.

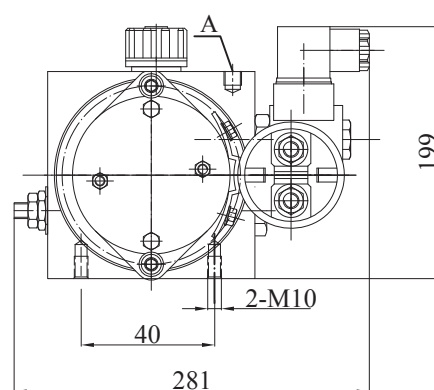
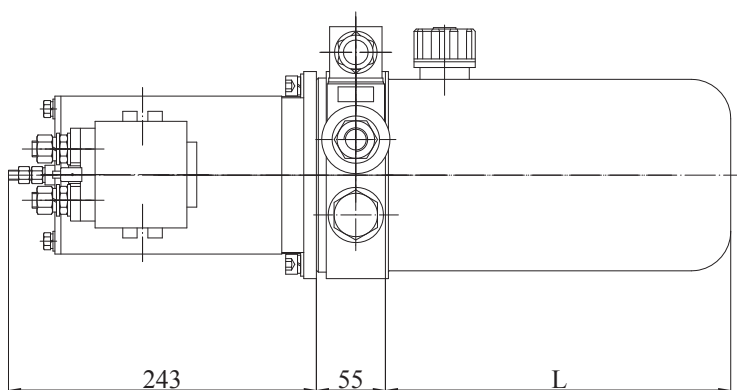

## 型号规格说明 Specifications

型号 Model	电机 Motor	泵排量 Disp.(cc/r)	油箱容积 Tank Cap.(L)	压力 Pressure(MPa)	安装方式 Installation	油口尺寸 Port Size	L(mm)
DC-F10-0.5/E-0.8/12/**-1H-C	12V 0.8Kw 3650RPM	0.5	1.0	16	卧式 Horizontal	G1/4	178
DC-F10-0.75/E-0.8/12/**-1.2H-C	12V 0.8Kw 3650RPM	0.75	1.2				210
DC-F10-0.5/E-0.8/24/**-1H-C	24V 0.8Kw 3650RPM	0.5	1.0				178
DC-F10-0.5/E-0.8/24/**-1.7H-C	24V 0.8Kw 3650RPM	0.75	1.7				170

说明: 1. 如需不同流量的泵、压力、电机功率等系统参数。请查看液压力单元型号说明。

2. 如需手动应急放油装置，请在订货时说明。

Introductions: 1. If need specifications like: pumps with different flow, pressure, motor power, please see the model introductions of hydraulic power unit.

2. If need hand emergent drain oil unit, please tell us when ordering products

## 注意事项 Notice

1. 此动力单元为S3工作制，不可连续运转，可重复工作。
2. 安装前必须保证油缸、油管、接头等液压元件清洁无任何杂质粘附。
3. 液压油粘度应为15-68CST，应清洁无杂质，推荐使用N46号液压油；若需全天候工作，必须使用航空液压油。
4. 本液压力单元为卧式安装。
5. 首次启动运行系统后，应立即检查油箱中的油量是否充足。
6. 系统使用第一个100小时后，应更换液压油，以后每3000小时更换一次液压油。

1. This power unit is S3 working type, can not work continuously, can work repeatedly.
2. Before installation, please be sure the cleanliness of component like tank, tube and fittings, without any impurities.
3. Viscosity of oil should be 15-68CST, should be clean and without impurities. Suggest to use N46 hydraulic oil. If need to work all-weather, must use aviation hydraulic fluid.
4. This power unit is horizontal installation.
5. After first work, oil tank should be checked immediately to see if there's enough oil.
6. After the first 100 working hour, hydraulic oil should be replaced. After that, the oil should be replaced every 3000 working hours.

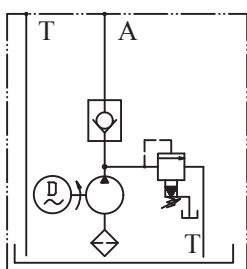

## 简介 FEATURES

此液压动力单元专为医疗设备中电动手术床设计, 噪音小, 低电流, 个体轻盈, 为手术床提供液压力源。同时适用于电动病床。

This hydraulic power unit is made up of motorized operating bed in medical equipment, low noise and electricity, light body, provide the power origin for operating bed, also used in electric bed.

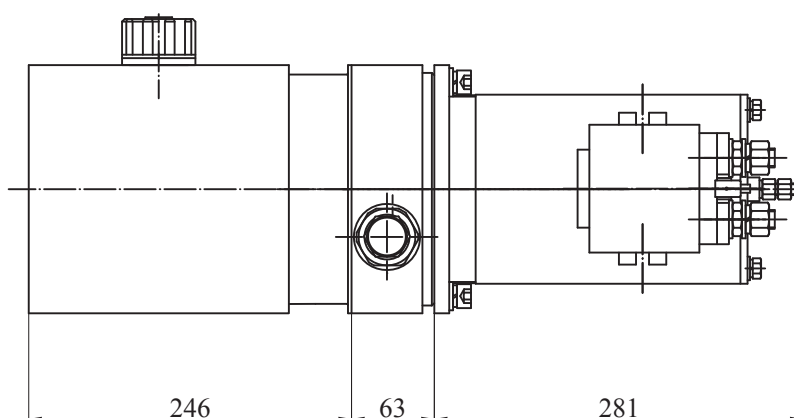
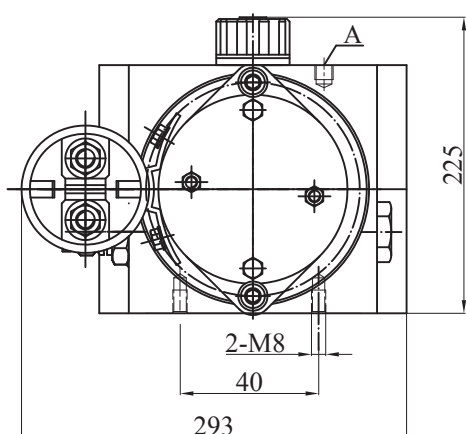

## 型号规格说明 Specifications

型号 Model	电机 Motor	泵排量 Disp.(cc/r)	油箱容积 Tank Cap.(L)	压力 Pressure(MPa)	安装方式 Installation	油口尺寸 Port Size
DC-F10-0.25/D-0.5/24/**-1H-C	24V 0.5Kw 2000RPM	0.25	1.0	10	卧式 Horizontal	G1/4
DC-F10-0.5/D-0.5/24/**-1H-C		0.5		6.5		

说明: 如需不同流量的泵、压力、电机功率等系统参数, 请查看液压力单元型号说明。

Introductions: If need specifications like: pumps with different flow, pressure, motor power, please see the model introductions of hydraulic power unit.

## 注意事项 Notice

1. 此动力单元为S3工作制, 不可连续运转, 可重复工作。
2. 安装前必须保证油缸、油管、接头等液压元件清洁无任何杂质粘附。
3. 液压油粘度应为15-68CST, 应清洁无杂质, 推荐使用N46号液压油; 若需全天候工作, 必须使用航空液压油。
4. 本液压力单元为卧式安装。
5. 首次启动运行系统后, 应立即检查油箱中的油量是否充足。
6. 系统使用第一个100小时后, 应更换液压油, 以后每3000小时更换一次液压油。

1. This power unit is S3 working type, can not work continuously, can work repeatedly.
2. Before installation, please be sure the cleanliness of component like tank, tube and fittings, without any impurities.
3. Viscosity of oil should be 15-68CST, should be clean and without impurities. Suggest to use N46 hydraulic oil. If need to work all-weather, must use aviation hydraulic fluid.
4. This power unit is horizontal installation.
5. After first work, oil tank should be checked immediately to see if there's enough oil.
6. After the first 100 working hour, hydraulic oil should be replaced. After that, the oil should be replaced every 3000 working hours.



F01

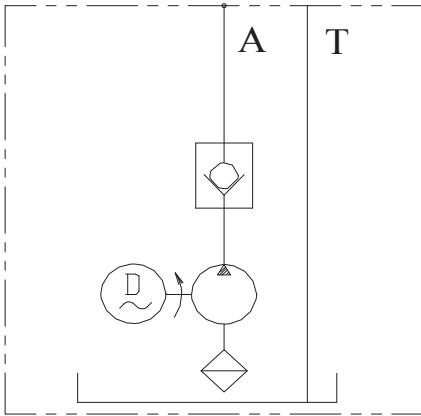

F02

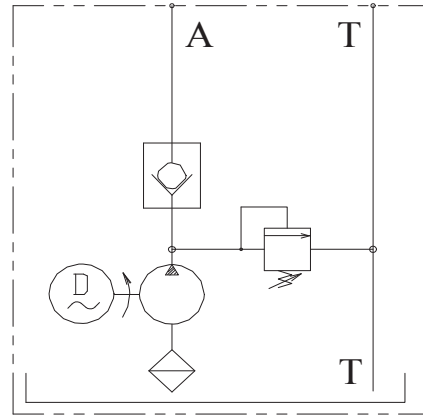

F03

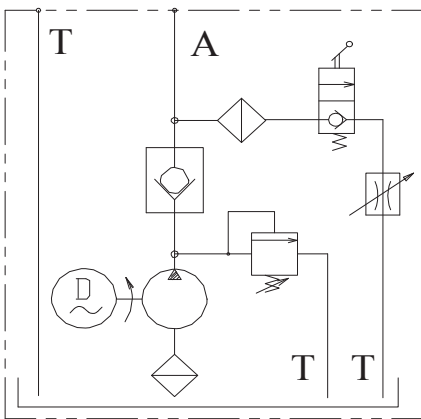

F04

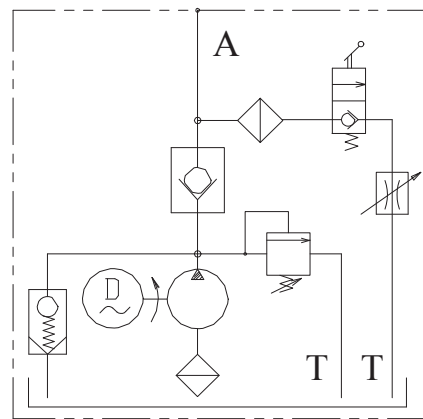

F05

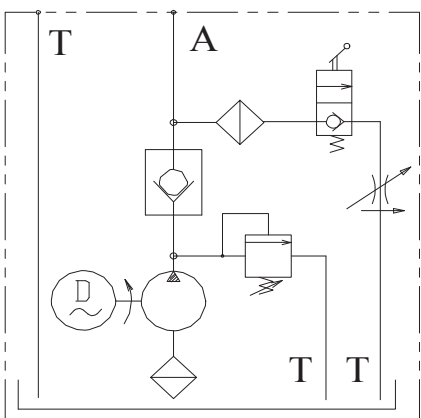

F06

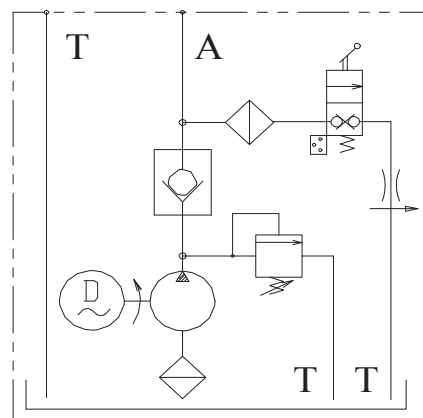

F07

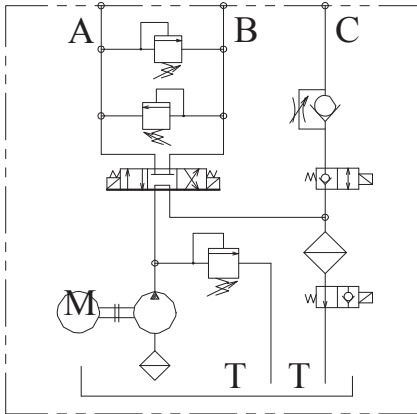

F08

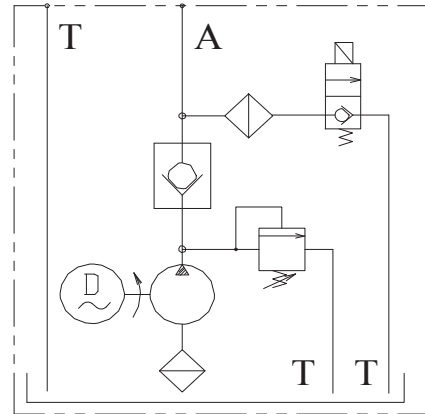

F09

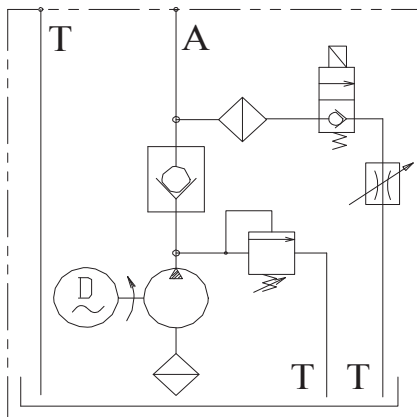

F10

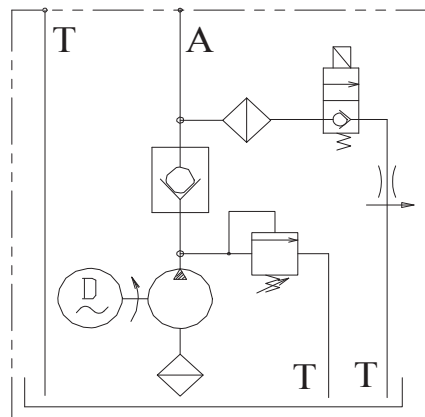

F11

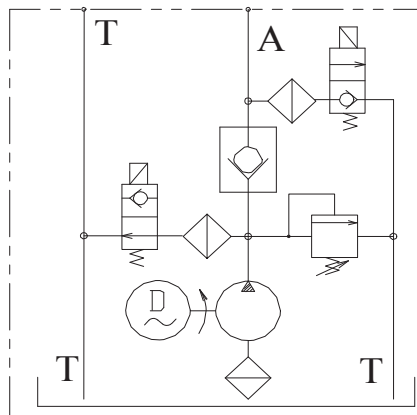

F12

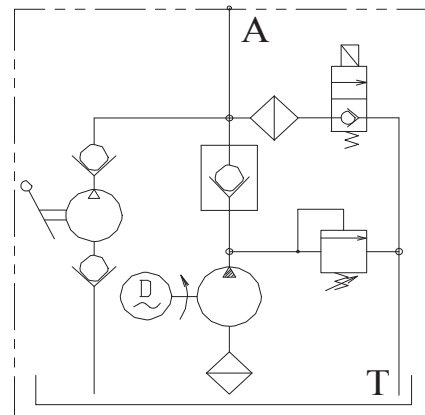

F13

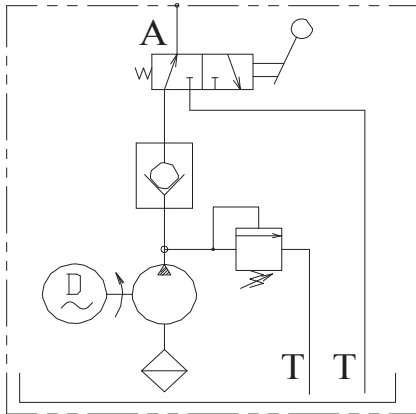

F14

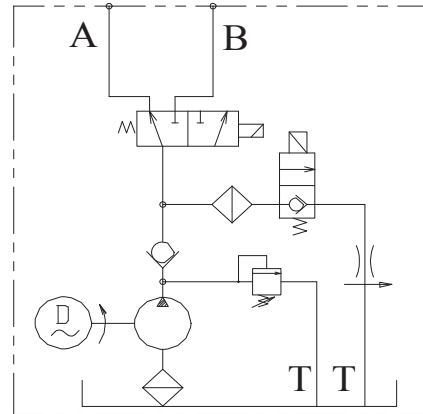

F15

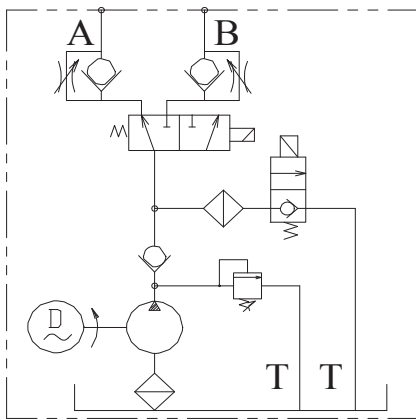

F16

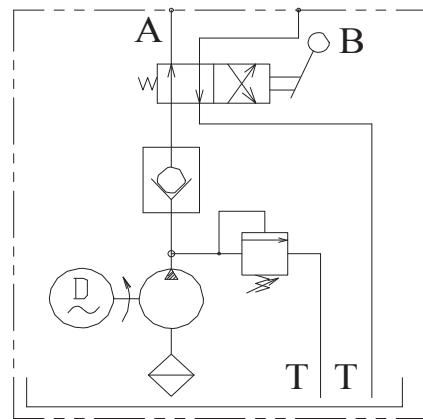

F17

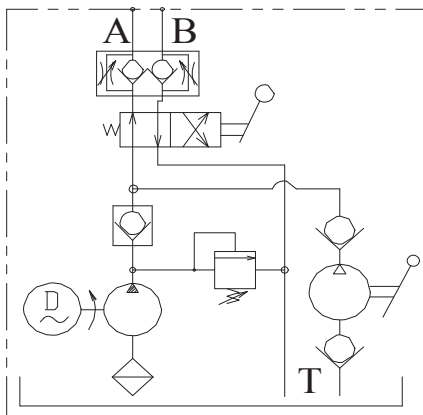

F18

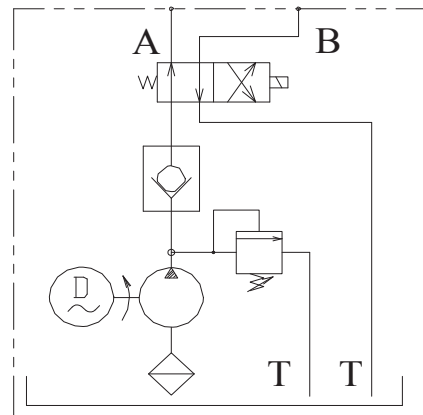

F19

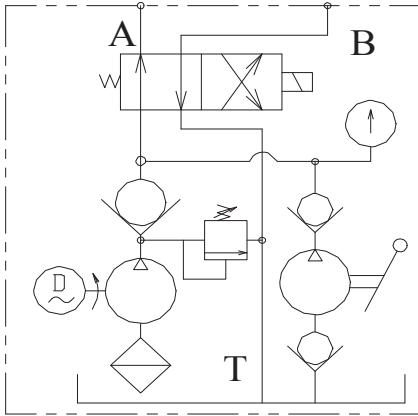

F20

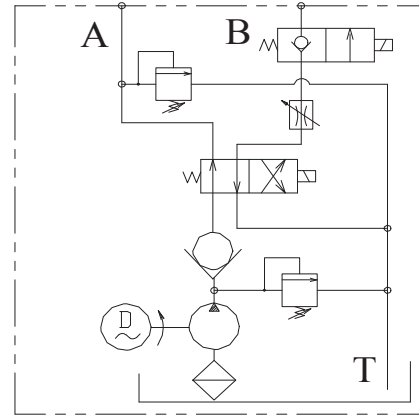

F21

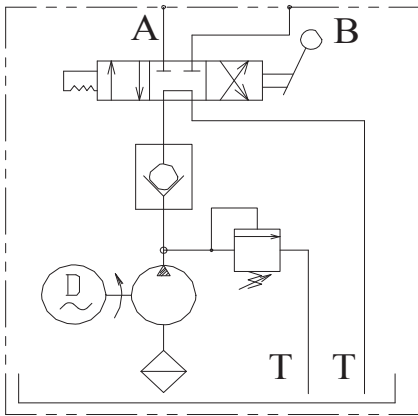

F22

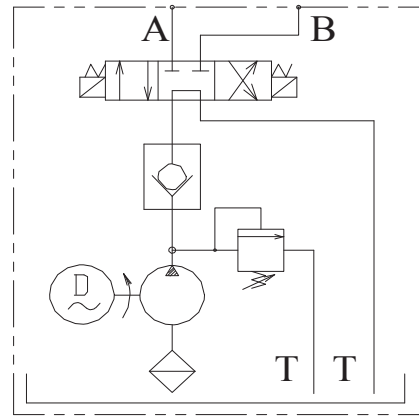

F23

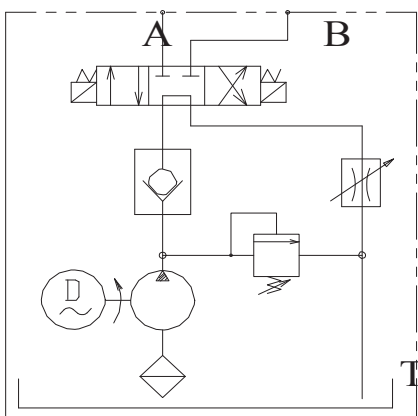

F24

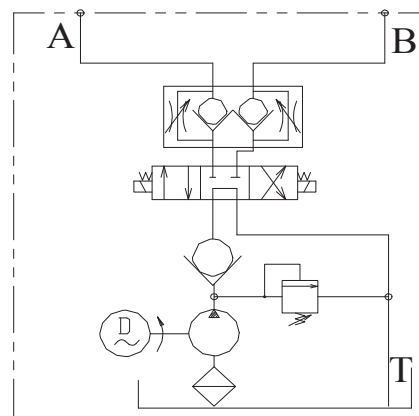

F25

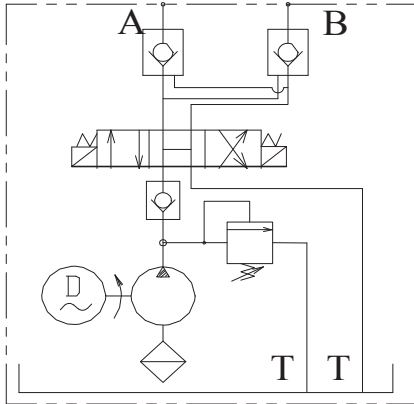

F26

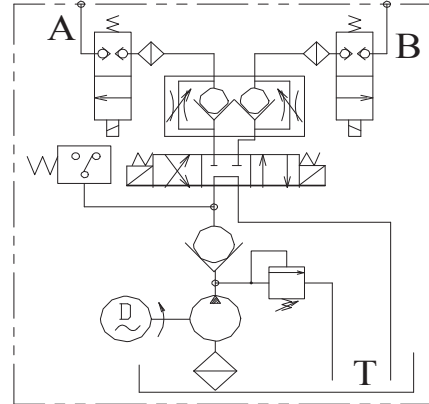

F27

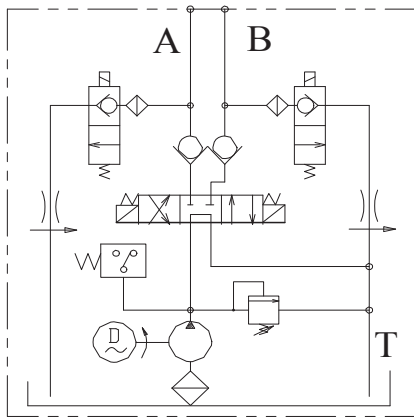

F28

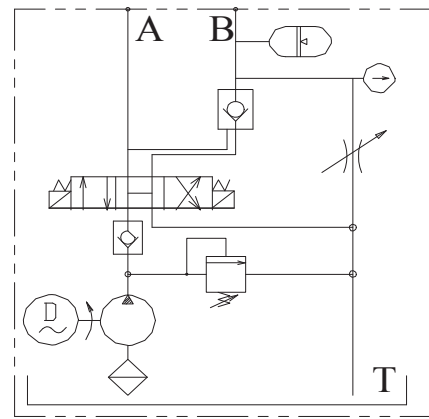

F29

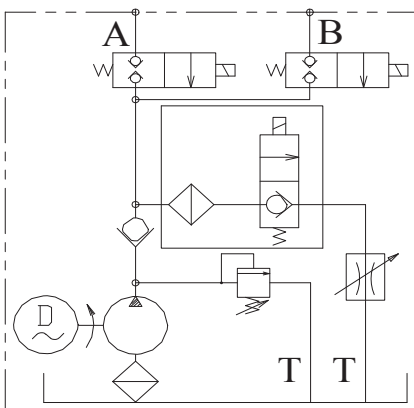

F30

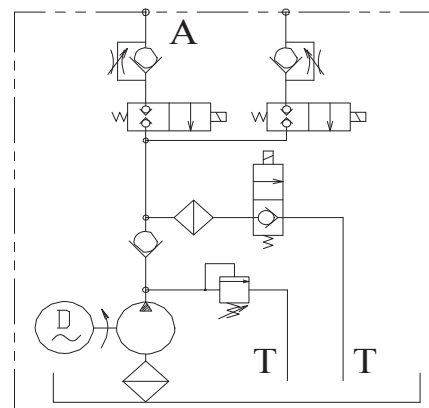

F31

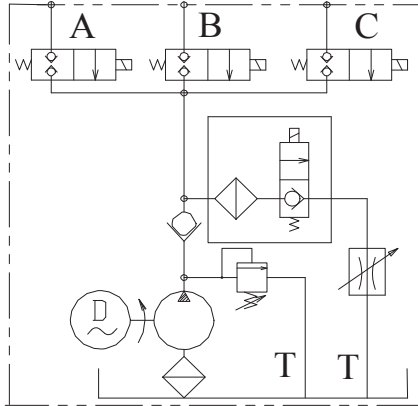

F32

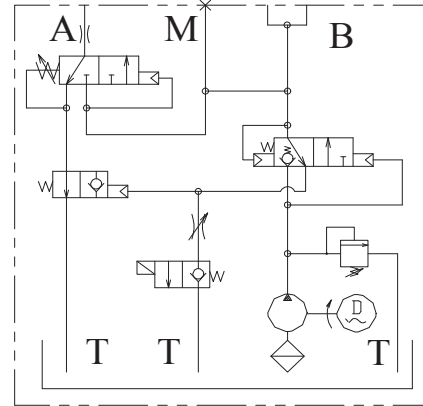

F33

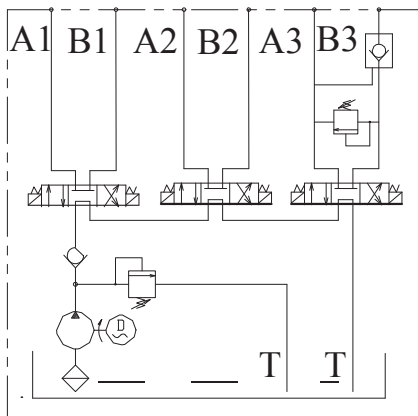

F34

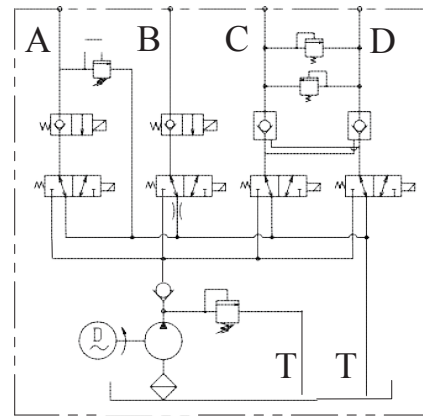

F35

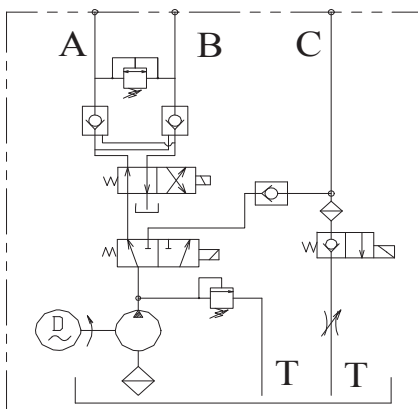

F36

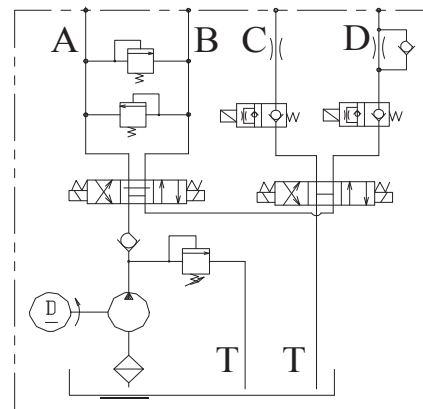

F37

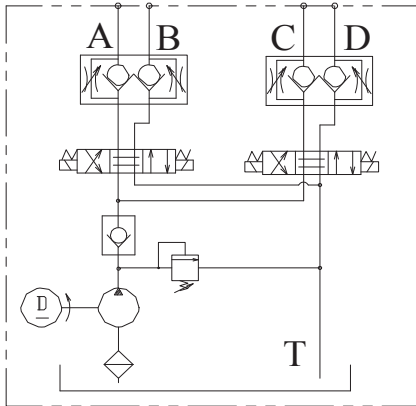

F38

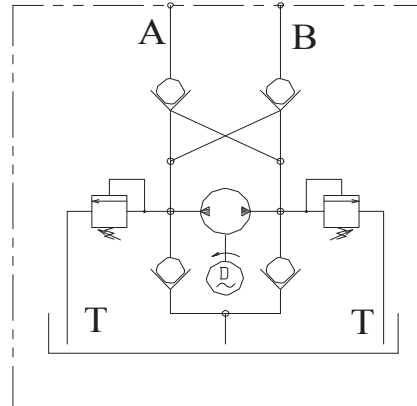

F39

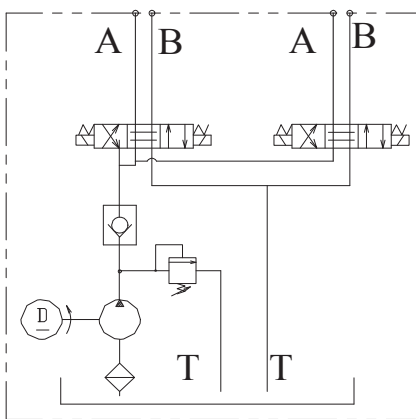

F40

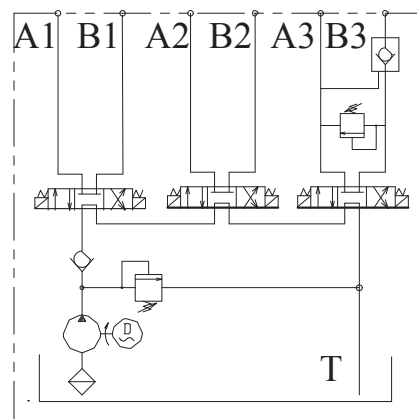

上海国瑞液压科技有限公司

SHANGHAI GUORUI HYDRAULIC TECHNOLOGY CO.,LTD

上海市虹口区四川北路1717号嘉杰国际广场2201-2202室

RM2201 JiaJie Building No1717 North Sichuan Road Shanghai China

电话/Tel:86-21-6218 3268 传真/Fax:86-21-6218 3018 邮编/P.C.:200080

Http://www.grhfluid.com Email: grh@grhcn.com

江苏国瑞液压机械有限公司

JIANGSU GUORUI HYDRAULIC MACHINERY CO.,LTD

江苏省建湖县高新区双湖西路666号

No. 666 West Shuanghu Road Hi-tech Zone Jianhu Jiangsu China

电话/Tel:86-515-8631 6688 传真/Fax:86-515-8631 7168 邮编/P.C.:224700

Http://www.grhpower.com Email: sales@grhcn.com